

# CM5441Z161B-10

**UNCONTROLLED DOCUMENT**

**PHYSICAL DIMENSIONS:**

A	13.72	[.540]	+ 0.20	[.008]
B	10.41	[.410]	+ 0.15	[.006]
C	15.24	[.600]	+ 0.25	[.010]
D	5.28	[.208]	+ 0.13	[.005]
E	6.35	[.250]	+ 0.10	[.004]

**WIRE DIMENSIONS:**

T1	3.05	[.120.]	+ 0.33	[.013]
T2	3.07	[.121]	+ 0.05	[.002]
T3	0.97	[.038]	+ 0.05	[.002]

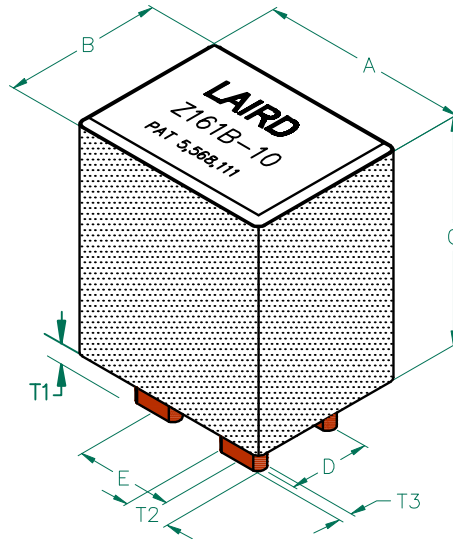

ELECTRICAL CHARACTERISTICS:		
Z @ 100MHz (Ω)	DCR (Ω)	Rated Current
Nominal	160	
Minimum	120	
Maximum	—	*75,000 mA

NOTES: UNLESS OTHERWISE SPECIFIED

1. BULK PACKED, 825 per CASE.
- 2.\* MAXIMUM CURRENT IS:  
30,000 mA @ 25° C RISE. 75,000 mA @ 30° C RISE.
3. COMPONENTS SHOULD BE ADEQUATELY PRE-HEATED BEFORE SOLDERING.
4. TERMINATION FINISH IS 100% TIN.

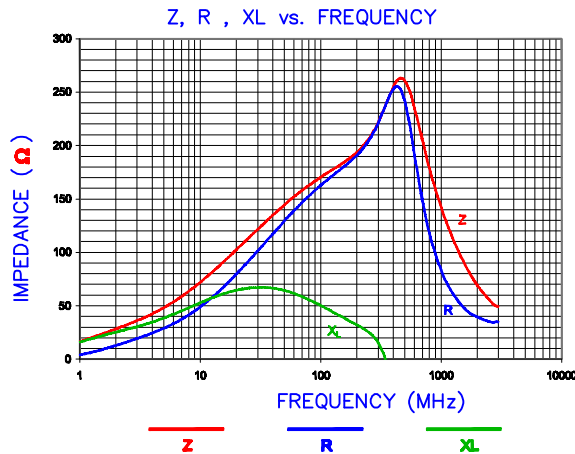
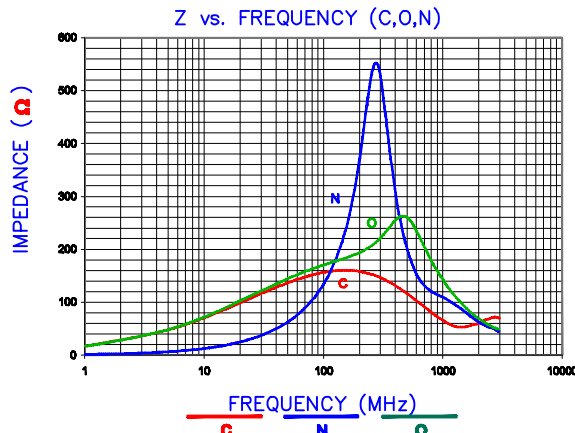

**EQUIVALENT CIRCUIT**

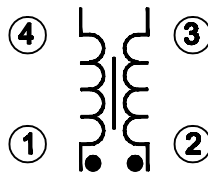

**HOLE PATTERN FOR WAVE SOLDERING**

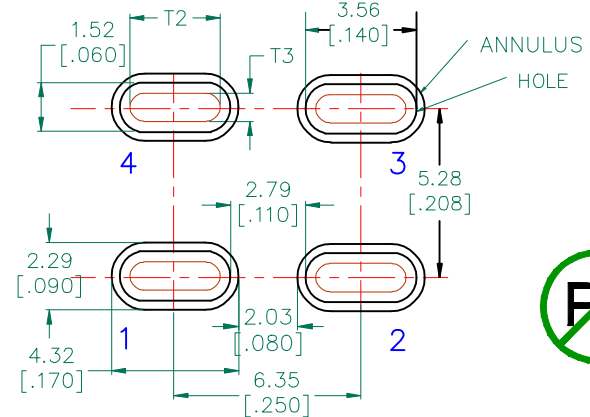

DIMENSIONS ARE mm IN [INCHES]				This print is the property of Laird Tech. and is loaned in confidence subject to return upon request and with the understanding that no copies shall be made without the written consent of Laird Tech. All rights to design or invention are reserved.	
E	UPDATE KAPTON LABEL	11/18/08	JRK	REV	E
D	CORRECT TOLS ON E DIMENSION	5/19/08	JRK	PROJECT/PART NUMBER:	CM5441Z161B-10
C	ADD EQUIVALENT CIRCUIT W/PIN NUMBERS UPDATE COMPANY LOGO	05/01/08	JRK	DATE:	05/24/04
B	UPDATE LOGO ADD ROHS SYMBOL	1/07/08	JRK	SCALE:	NTS
A	ORIGINAL DRAFT	05/24/04	JRK	MATERIAL:	
REV	DESCRIPTION	DATE	INT	CAD #	CM5441Z161B-10-E-2
				TOOL #	H0540-1
				DRAWN BY:	JRK
					2 OF 3